

DK Snap-in Terminal Type, High Temperature Series

- Endurance : 2.5V 85°C 1500 hours
- The middle size and high capacitance, low resistance
- Charge and discharge efficiency are higher than in batteries



Item	Characteristics	
Operating temperature range	-40 ~ +85°C	
Rated Voltage	2.5 VDC	
Capacitance tolerance	0% ~ +20%	
Temperature characteristics	Capacitance change	Within $\pm 5\%$ of initial value at +20°C
	Internal resistance change	Within 50% of initial value at +20°C
Endurance (85°C)	Test time	1500 hours
	Capacitance change	Within $\pm 30\%$ of specified value
	Internal resistance change	Less than 100% of specified value
Shelf life (85°C)	After 1500 hours no load test same as endurance	
Life Time at RT ⁽¹⁾	10 years	(1) $ \Delta C < 30\%$ and $\Delta ESR < 100\%$ of specified value, respectively and $LC <$ specified value
Cycle Life (25°C) ⁽¹⁾⁽²⁾	500,000 cycles	(2) Cycle : between rated voltage and half rated voltage under constant current at 25°C

DRAWING

Unit : mm

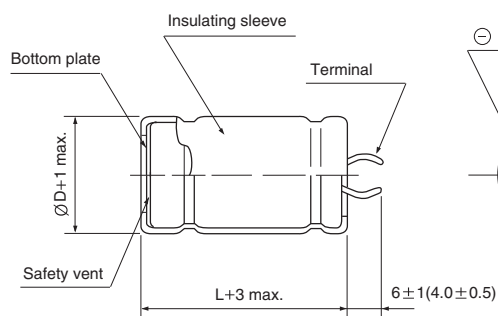

PC Board Mounting Holes

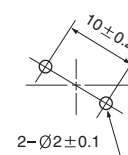

Terminal

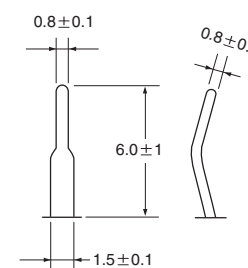

CHARACTERISTIC LIST & DIMENSIONS

Rated Voltage	Capacitance (F)	ESR, 1KHz (mΩ)	ESR, DC (mΩ)	LC (72hr) (mA Max.)	Max Continuous Current(A)	Max Peak Current(A)	Specific Energy		Weight (g)	Volume (ml)	Dimension ØD×L(mm)
							(Wh/kg)	(Wh/L)			
2.5	100	8.0	10.0	0.25	5.3	63	4.13	5.07	21	17	22 × 45
	200	7.0	9.0	0.50	10.6	89	4.57	5.46	38	32	30 × 45
	300	3.5	5.0	0.75	15.8	150	4.57	5.41	57	48	35 × 50
	360	3.2	3.8	0.90	19	190	4.46	5.41	70	58	35 × 60
	400	3.2	3.8	1.00	21.1	198	4.96	6.01	70	58	35 × 60

* Ø35 4pin type terminal drawing is same see pages 200.